



**AUSTRALIAN  
WEIGHING  
EQUIPMENT**

*Weigh ahead in Weighing*

PRODUCT GUIDE

# ECHIDNA BENCH SCALE

- High accuracy
- High capacity
- Affordable solution





## ■ ABOUT THE ECHIDNA BENCH SCALE

The Echidna Bench Scale is a high capacity and accuracy scale that has been designed to suit a vast array of businesses from food processing, manufacturing, shipping sending/receiving to even hostile work environments.

One would ordinarily expect to pay thousands of dollars for a scale with such high accuracy and capacity, but AWE group can offer this as an affordable solution to your company because of their research and development in the latest scale technologies.

The Echidna Bench Scale offers up to 60kg capacity and internal resolution of: 1/6000,000

The low profile Echidna Bench Scale also comes in 15kg and 30kg, with a 360 x 320mm stainless steel platter.



## ■ FEATURES

- Internal resolution: 1/600,000
- Tare and zero function
- Low battery warning indicator
- Battery provides 40 hours of continuous use (without backlight)
- Stainless steel platter
- Easy to use
- 12 month guarantee
- 240v or battery option
- Net / Gross functionality
- Weighing units in kilograms or grams
- The RS-232 output enables communication with a PC, printer or other peripheral device
- Delivered and fully calibrated





■ **SPECIFICATIONS**

Order Code	ECHIDNA-15KG	ECHIDNA-30KG	ECHIDNA-60KG
Capacity	15kg	30kg	60kg
Resolution	0.2g	0.5g	1g
Max Division	75,000e	60,000e	
Pan Size	320 x 360mm		
Gross Weight	9kg		
Display	22mm digit LCD display, with white LED backlight		
Keyboard	6 Keys (mechanical switch)		
Housing	ABS Plastic Indicator, Stainless Steel Platter		
Power	AC adapter (12V/500mA), Ni-MH battery (1.2V/20002Ah x 6)		
ADC Update Sigma Delta	Sigma Delta		
Operating Temp	-10°C~+40°C		
Approvals	CE		

■ **OPTIONS**

Order Code	Description
PS-101	Spare power packs for recharging 12v500mA

■ **DIMENSIONS**

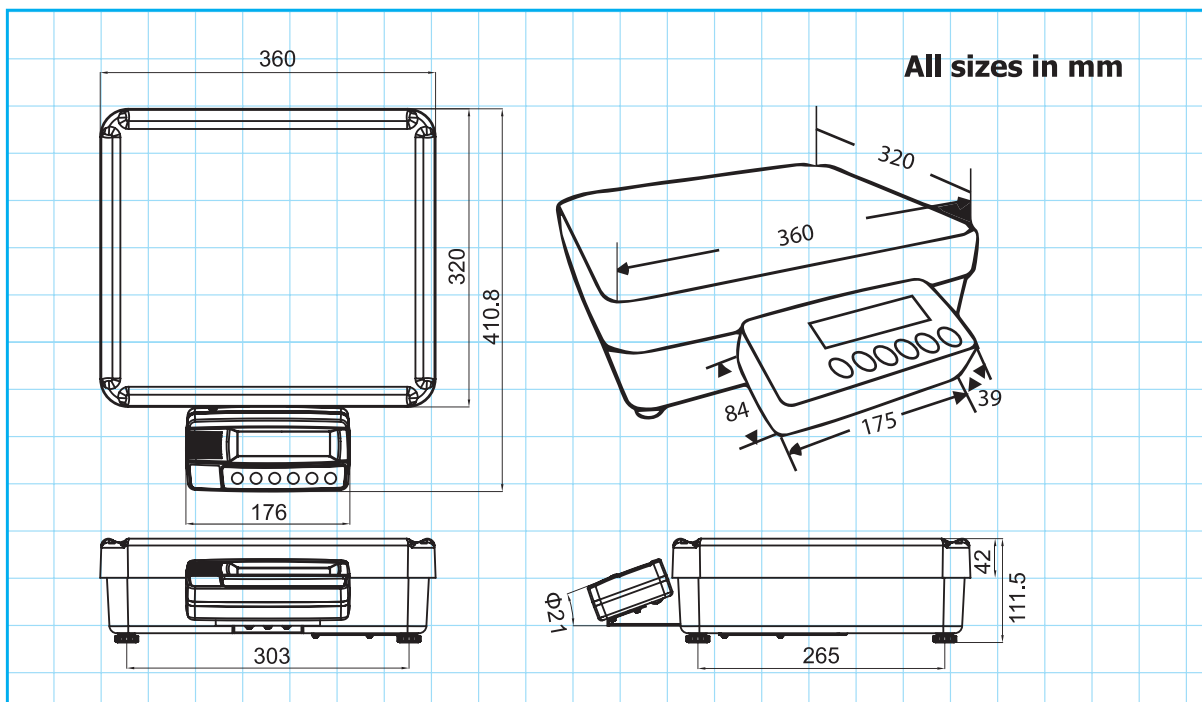



### ■ AWE - THE BEST IN THE BUSINESS

AWE has built a reputation in providing world class products and services to customers from a wide range of industries for many unique applications. All the products come with AWE Quality Guarantee- giving you the assurance that they have been tested to meet or exceed the specifications and requirements of your application.

At AWE, it's more than just delivering perfectly-designed equipment, it also requires a team of dedicated people who will back you up with great service and support. Any servicing, installation and technical support issues you encounter can be addressed either onsite or remotely by our engineers and tradesmen who are qualified as:

- Licensed Tradesmen
- Mechanical Engineers
- Electrical Engineers
- Structural Engineers
- Draftsmen
- Fitter & Turners
- Boilermakers
- Fully Qualified Scale Makers
- Electronic Technicians
- Instrument Fitters
- Electricians
- Service Technicians
- Project Managers
- Formworkers
- Concreters



Call AWE today. We will find the right solution for your individual needs.

### ■ AWE PRODUCT RANGE



Weighbridges



Load Cells

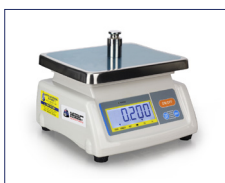

Scales



Crane Scales



Indicators



Packaging Equipment



Onboard Weighing



Batching Consoles



Test Weight



Maintenance

If you have questions about

- **weighing equipment**
- **packaging equipment**
- **bulk materials handling**
- **componentry**

call the sales team at *AWE Group* to find the right solution for your individual needs.



## ■ WHO IS “AUSTRALIAN WEIGHING EQUIPMENT GROUP”

Jeff & Trevor Baillie started Australian Weighing Equipment (or AWE) in 1981, focusing on weighing solutions based on engineering principles. Over 40 years, AWE has built its reputation as a leading supplier of robust weighing, packaging & bulk handling equipment. Our innovative engineering and continuous product developments have led to designs that will stand up to the rigours and demands of your applications.

AWE has increased its investment in manufacturing facilities with a new 3,200sq/m factory in Sydney featuring;

- A CNC Machine Shop
- Heavy Metal Fabrication Shop
- Larger work areas for our team of qualified tradesman

Acquisitions of Bradwood Packaging and Dendy Packaging and Design Engineering has increased our packaging and engineering experience.

In 2008, AWE established a manufacturing facility in China - AWE Group Packaging and Bulk Materials Handling Equipment, a purpose-built 5,000sq/m factory in Suzhou China (70kms From Shanghai).

All of the products we offer are Australian designed and manufactured under our strict quality control system in our own factories both locally and internationally.

## ■ AUSTRALIAN WEIGHING EQUIPMENT OFFICE LOCATIONS



Australian Weighing  
Equipment - Sydney Office

8 Heald Road  
Ingleburn NSW 2565



Australian Weighing  
Equipment - Brisbane Office

7 Darnick Street  
Underwood, QLD 4119



Australian Weighing  
Equipment - Melbourne Office

37 Barrie Road  
Tullamarine, VIC, 3043



Australian Weighing  
Equipment - Melbourne Office

27 Rhur St,  
Dandenong South VIC 3175

## ■ AUSTRALIAN WEIGHING EQUIPMENT ON SOCIAL MEDIA



@AustralianWeighingEquipment



www.awe.com.au



/company/awegrouppaustralia



www.youtube.com/AustWeighing



@australianweighingequipment

Dealer's Information:

SCAN HERE



www.awe.com.au